

USE COPPER CONDUCTORS ONLY

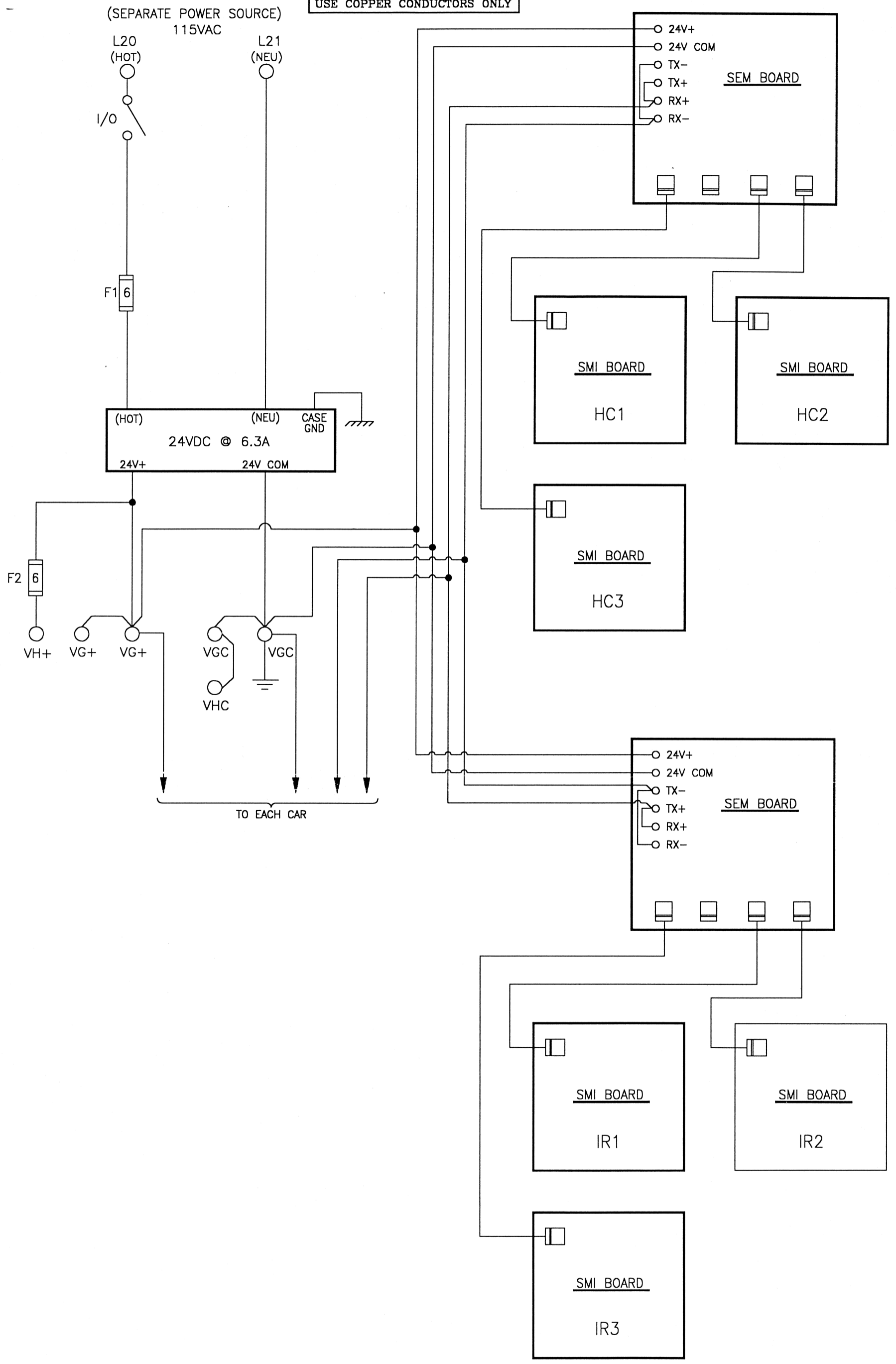

HALL CALL INTERFACE ON REMOTE GROUP ENCLOSURE

DRAWING NUM
152

COMPUTERIZED ELEVATOR CONTROL CORP.
636 11TH AVENUE NEW YORK, NEW YORK 10036 TEL. (212) 397-0606

| | | |
|--|-------------------|------------------|
| JOB NAME/LOC.: EMBASSY SQUARE SUITES WA, DC (AMTECH) | | |
| DATE: 04/12/96 | CEC JOB NO. 2989 | CAR NO. 1 THRU 4 |
| DRAWN BY: NF | DWG. NO. 152HCALL | REV. 11-10-94 |

05/05/96 08:54 E:\JOBS\2900\2989\152HCALL.DWG